



Electronics 1

BSC 113

Fall 2022-2023

Lecture 1

Introduction

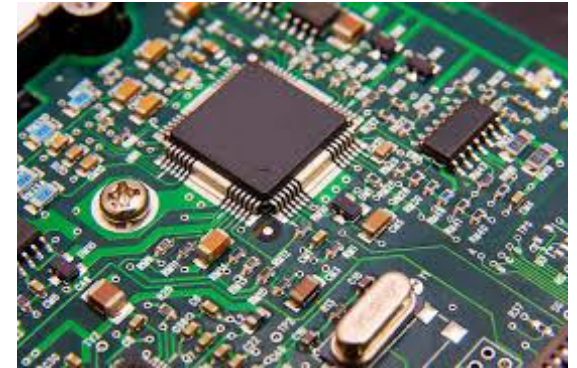
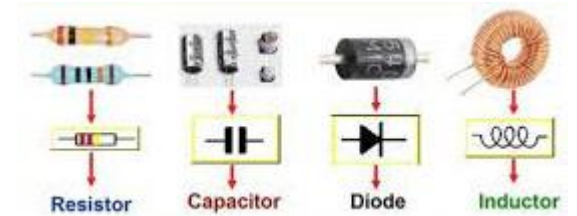

INSTRUCTOR

DR / AYMAN SOLIMAN

➤ Contents

- 1) Course Contents.
- 2) Grading System & distribution.
- 3) Course Information.
- 4) Course Policy.
- 5) List of Symbols
- 6) Acronyms



1) Course Contents.

- **Basic concepts:** SI Units, SI prefixes, charge, current, voltage, power, energy, active elements and passive elements.
- **Basic laws:** ohm's law, conductance, Node, branch, Kirchhoff's current law (KCL), Kirchhoff's voltage law (KVL), Series resistance, voltage division, Parallel resistance and current division.



1) Course Contents (cont.)

➤ Electrical circuit analysis method and Circuit theorem:

Nodal analysis (elimination technique, Cramer's rule, Super node and inspection method for nodal analysis),

mesh analysis (Cramer's rule and inspection method for mesh analysis), Superposition, Source transformation, Thevenin's theorem, Norton theorem and Maximum power transfer.



1) Course Contents (cont.)

➤ Inductors, Capacitors and Transient circuits:

Inductors, Capacitors, **First order** transient circuit (Source free R-C circuit, Forced R-C circuit, Source free R-L circuit and Forced R-L circuit)

and **Second order** transient circuit (R-L-C circuit).

➤ Sinusoidal steady state analysis: Phasors and sin wave, Electrical circuit analysis, Circuit theorems and Average and RMS.



1) Course Contents (cont.)

➤ Electronic part:

Semiconductors and diode: Material types and properties of semiconductors,

Doping process, N-type and P-type, P-N junction,

Models for diode

Diode applications (HWR and FWR).



2) Grading System & distribution.

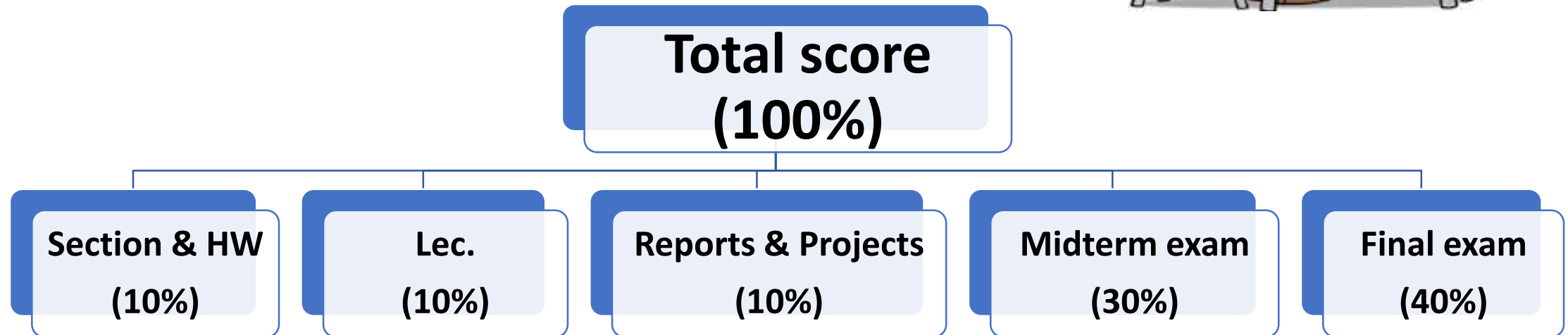

3) Course Information.

Lecture: Saturday (09:00 AM - 11:25 AM), (11:25 AM - 13:50 PM)

References:

- Lecture Notes Dr\ Ayman Soliman 2022.
- Microelectronic Circuits, Seventh edition Adel S. Sedra, University of Waterloo Kenneth, C. Smith University of Toronto.

Instructor:

Dr. Ayman Soliman
ayman.mohamed01@bhit.bu.edu.eg

TAs:

Eng.

4) Course Policy.

- Be **on time** and cell phones should be silent or off during the lecture.
- Any forms of **cheating or plagiarism** will result in a **Zero grade** for the required task, report or exam (No discussion nor excuses).
- Students are expected to **respect** Instructors, TAs, and their colleagues.
- Your grades is based on **merit only** nothing else.



5) List of Symbols

A	Ampere
C	Capacitance
D	Diode
E	Energy
I	Electrical current
J	Imaginary
L	Inductance
P	Power
R	Resistance
V	Volt
ϵ	Permittivity
μ	Mobility
δ	Partial differentiation
ϕ	Angle

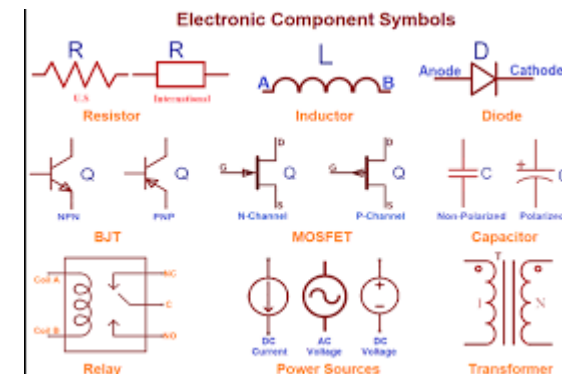
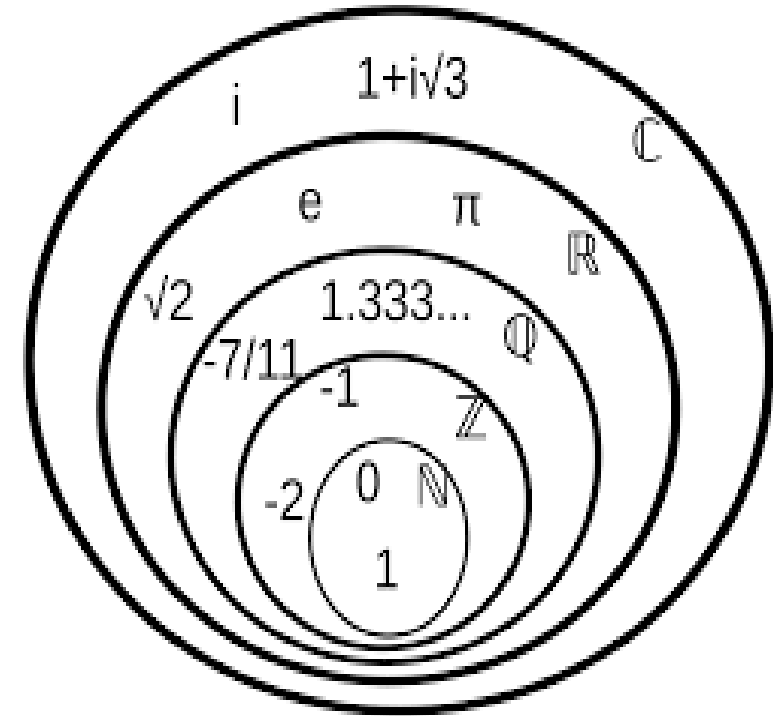

6) Acronyms

Avg	Average
F. B	Forward Bias
FWR	Full Wave Rectifier
HWR	Half Wave Rectifier
KCL	Kirchhoff's Current Law
KVL	Kirchhoff's Voltage Law
RMS	Root Mean Square
R. B	Reverse Bias

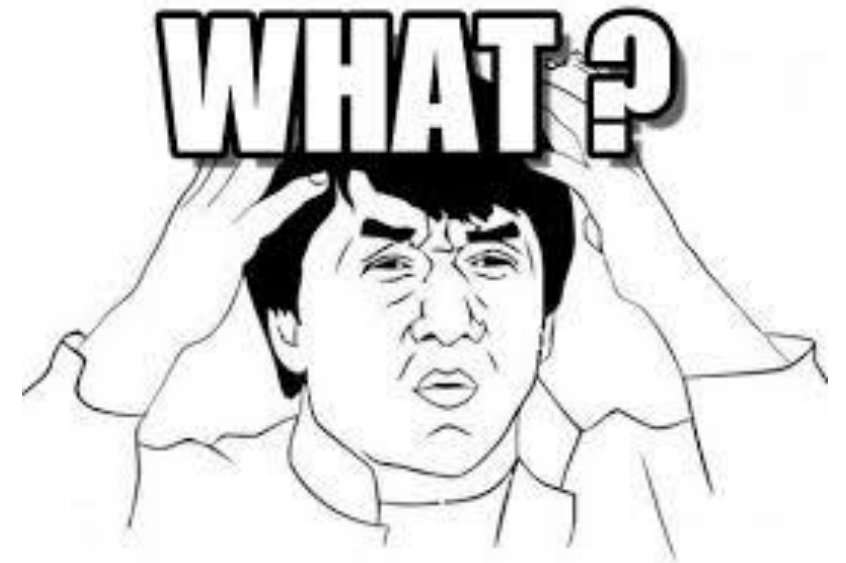

Thank
you

